

CAST STEEL CHECK VALVE – ANSI CLASS 600

DESIGN DESCRIPTION:

- BOLTED COVER
- SWING TYPE
- FOR HORIZONTAL OR VERTICAL LINES
- RENEWABLE SEAT RING
- FLANGED ENDS
- BUTTWELDING ENDS

APPLICABLE STANDARDS:

- STEEL VALVES, ANSI B16.34
- FACE TO FACE, ANSI B16.10
- END FLANGES, ANSI B16.5
- BUTTWELDING ENDS, ANSI B16.25
- INSPECTION AND TEST, API 598

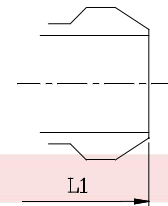
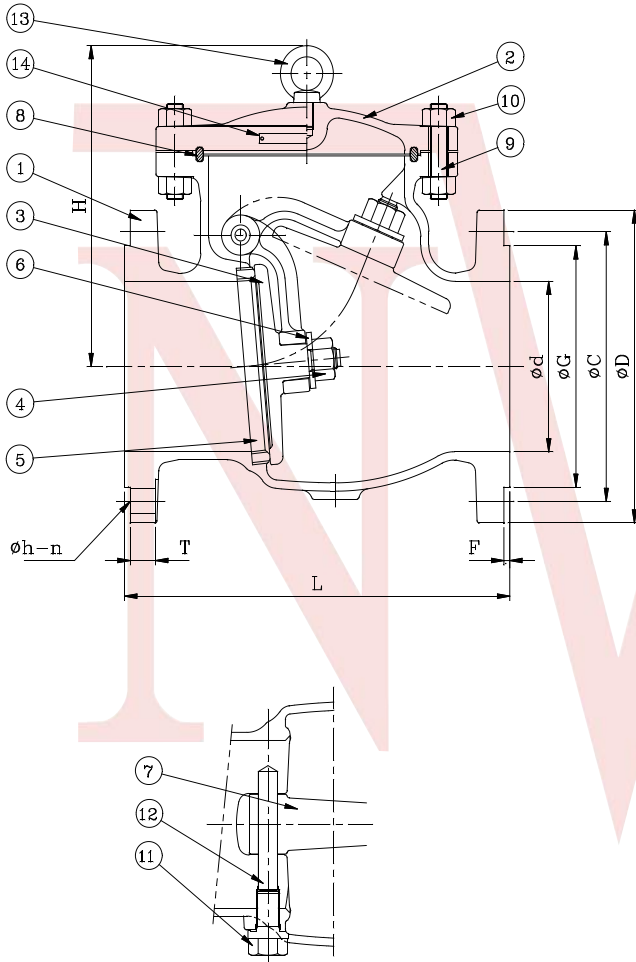

Buttwelding Ends

PARTS AND MATERIAL (ASTM)

NO.	PARTS NAME	MATERIALS		
		WCB	WC6	LCB
1	Body	A216-WCB	A217-WC6	A352-LCB
2	Cover	A216-WCB	A217-WC6	A352-LCB
3	Disc	A216-WCB+H/F 410	A217-WC6+H/F 410	A352-LCB+H/F 410
4	Disc Nut	A194-8		
5	Seat Ring	A105+H/F STL#6	A217-WC6+H/F STL#6	A350-LF2+H/F STL#6
6	Disc Washer	A276-304		
7	Swing Arm	A216-WCB	A217-WC6	A352-LCB
8	Gasket	Soft Iron		
9	Cover Bolt	A193-B7	A193-B7	A193-B7M
10	Cover Bolt Nut	A194-2H	A194-2H	A194-2HM
11	Plug	A276-410		
12	Hinge Pin	A276-410		
13	Eye Bolt	A36		
14	Name Plate	A666-304		

OTHER MATERIALS ARE AVAILABLE UPON REQUEST.

TEST PRESSURE TO API 598

PSIG		
SHELL TEST (water)	SEAT TEST (water)	SEAT TEST (air)
2225 (156 kg/cm ²)	1628 (114 kg/cm ²)	80 (6 kg/cm ²)

DIMENSION TABLE:

DN	NPS	Ø d	L & L1	H	T	F	Ø D	Ø C	Ø G	Ø h	n	WT.(Kg)
50	2	50.8	292	203	25.4	6.4	165.1	127.0	92.0	19.0	8	34
65	2 1/2	63.5	330	210	28.5	6.4	190.5	149.4	104.7	22.3	8	45
80	3	76.2	356	235	31.8	6.4	209.6	168.2	127.0	22.3	8	63
100	4	101.6	432	286	38.1	6.4	273.1	215.9	157.2	25.4	8	114
150	6	152.4	559	330	47.8	6.4	355.6	292.1	215.9	28.5	12	207
200	8	200.2	660	381	55.6	6.4	419.1	349.3	269.8	31.8	12	364
250	10	247.7	787	457	63.5	6.4	508.0	431.8	323.9	35.0	16	560
300	12	298.5	838	584	66.5	6.4	558.8	489.0	381.0	35.0	20	792
350	14	326.9	889	635	69.8	6.4	603.3	527.1	412.8	38.1	20	1082
400	16	374.6	991	693	76.2	6.4	685.8	603.3	469.9	41.2	20	1253