

CAST STEEL GATE VALVES – ANSI CLASS 1500

DESIGN DESCRIPTION:

- OUTSIDE SCREW AND YOKE
- PRESSURE SEAL BONNET
- FLEXIBLE WEDGE, FULLY GUIDED
- RENEWABLE SEAT RINGS
- RISING STEM AND NON-RISING HANDWHEEL, GEAR OPERATOR
- AVAILABLE WITH BY-PASS VALVE
- FLANGED ENDS
- BUTTWELDING ENDS

APPLICABLE STANDARDS:

- STEEL VALVES, ANSI B16.34
- FACE TO FACE, ANSI B16.10
- END FLANGES, ANSI B16.5
- BUTTWELDING ENDS, ANSI B16.25
- INSPECTION AND TEST, API 598

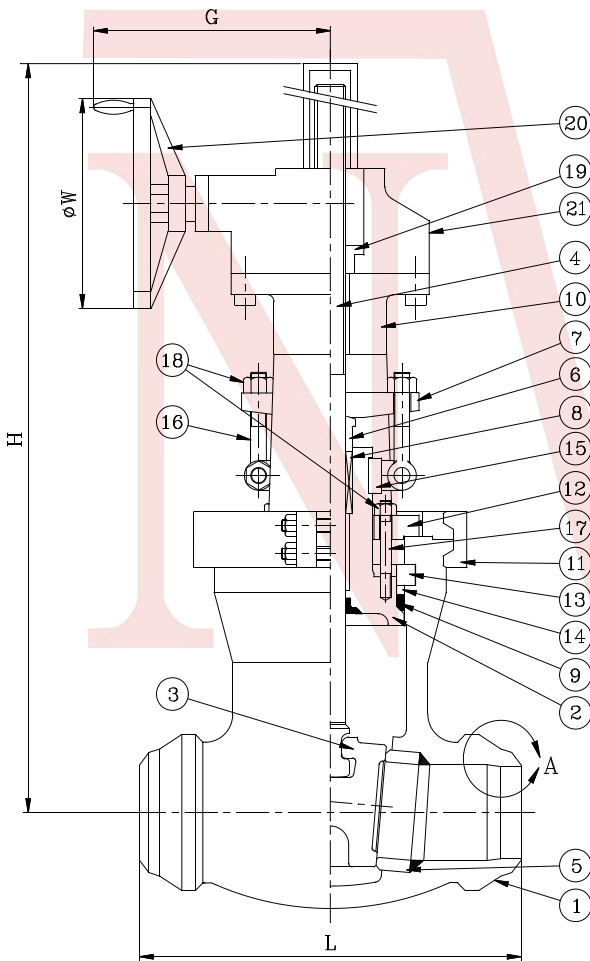
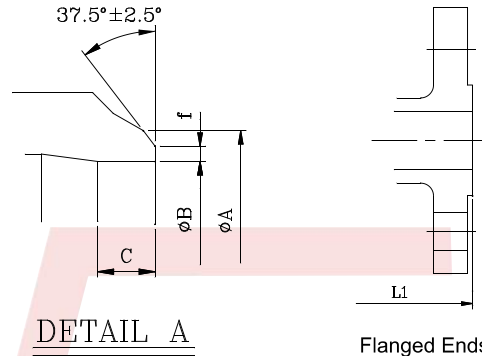

PARTS AND MATERIAL (ASTM)

NO.	PARTS NAME	MATERIALS		
		WCB	WC6	LCB
1	Body	A216-WCB	A217-WC6	A352-LCB
2	Bonnet	A216-WCB	A217-WC6	A352-LCB
3	Disc	A216-WCB+H/F STL#6	A217-WC6+H/F STL#6	A352-LCB+H/F STL#6
4	Stem	A182-F6a		
5	Seat	A105+ H/F STL#6	A182-F6a+H/F STL#6	A352-LF2+H/F STL#6
6	Gland	A276-410		
7	Gland Flange	A216-WCB		
8	Gland Packing	Grafoil		
9	Gasket (P.S.)	Soft Iron + Silver Plated		
10	Yoke	A216-WCB		
11	Yoke Clamp	A216-WCB	A217-WC6	A352-LCB
12	Bonnet Retainer	A216-WCB		
13	Retainer Ring	A182-F6		
14	Spacer Ring	A182-F6		
15	Eye Bolt Clamp	A216-WCB		
16	Eye Bolt	A193-B7		
17	Bolts	A193-B7	A193-B7	A193-B7M
18	Nuts	A194-2H	A194-2H	A194-2HM
19	Stem Nut	A439-D2		
20	Hand Wheel	A536		
21	Bevel Gear	Commercial		

OTHER MATERIALS ARE AVAILABLE UPON REQUEST.

TEST PRESSURE TO API 598

PSIG

SHELL TEST (water)	SEAT TEST (water)	SEAT TEST (air)
5575 (391 kg/cm ²)	4076 (286 kg/cm ²)	80 (6 kg/cm ²)

DIMENSION TABLE:

DN	NPS	L & L1	H	Ø W	G	Ø A	Ø B	C	f	WT.(Kg)
150	6	559	1043	610	337	172	132	20	1.6	390
200	8	711	1285	610	337	223	173	20	1.6	640
250	10	864	1580	610	512	278	216	20	1.6	980
300	12	991	1880	750	512	329	257	20	1.6	1280